

USER'S MANUAL

MPPT Solar Charge Controller

USER'S MANUAL

MPPT Solar Charge Controller

45A/60A

Warranty Summary

Dear Customer,

Thank you for your purchase of our products. We make every effort to assure our power conversion products will give you long and reliable service for your renewable energy system.

As with any manufactured device, repairs might be needed due to damage, inappropriate use, or unintentional defect. Please note the following guidelines regarding warranty service of our products:

- Any and all warranty repairs must conform to the terms of the warranty.
- All our equipment must be installed according to their accompanying instructions and manuals with specified over-current protection in order to maintain their warranties.
- The customer must return the component(s) to us, securely packaged, properly addressed, and shipping paid. We recommend insuring your package when shipping. Packages that are not securely packaged can sustain additional damage not covered by the warranty or can void warranty repairs.
- There is no allowance or reimbursement for an installer's or user's labor or travel time required to disconnect, service, or reinstall the damaged component(s).
- In the event of a product malfunction, we cannot bear any responsibility for consequential losses, expenses, or damage to other components.
- Please read the full warranty at the end of this manual for more information.

Notice of Copyright

The series MPPT Solar Charge Controller User's Guide: Installation, Programming and User's Manual
Copyright © 2014 All rights reserved.

Disclaimer

UNLESS SPECIFICALLY AGREED TO IN WRITING:

- (a) MAKES NO WARRANTY AS TO THE ACCURACY, SUFFICIENCY OR SUITABILITY OF ANY TECHNICAL OR OTHER INFORMATION PROVIDED IN ITS MANUALS OR OTHER DOCUMENTATION.
- (b) ASSUMES NO RESPONSIBILITY OR LIABILITY FOR LOSS OR DAMAGE, WHETHER DIRECT, INDIRECT, CONSEQUENTIAL OR INCIDENTAL, WHICH MIGHT ARISE OUT OF THE USE OF SUCH INFORMATION. THE USE OF ANY SUCH INFORMATION WILL BE ENTIRELY AT THE USER'S RISK.

Date and Revision

August, 2014 REV A2

FOLLOW STANDARD

EN 60950-1:2006+A2:2013+A11:2009+A1:2010+A12:2011
EN 55022:2010, EN 55024:2010, EN 61000-3-3:2008

Contents

SCOPE 1

INTRODUCTION	1
THE CHARGE CONTROLLER INSTALLATION GUIDELINES AND SAFETY INSTRUCTIONS	3
1. INSTALLING THE CHARGE CONTROLLER.....	6
2. OPEN CIRCUIT VOLTAGE/WIRE AND DISCONNECT SIZE	7
3. CHARGE CONTROLLER WIRING CONNECTIONS	8
4. THE CHARGE CONTROLLER SCREEN DESCRIPTION	12
5. POWER UP	13
6. STATUS SCREEN	13
7. RECHARGING USING THE PV ARRAY	15
8. ACCESSING THE MAIN MENU FOR PARAMETER SETTING.....	16
9. CHARGE CONTROLLER MULTI STAGE BATTERY CHARGING BRIEF INTRODUCTION	19
10. CHARGE CONTROLLER EFFICIENCY VS. INPUT POWER GRAPH	20
11. TROUBLESHOOTING GUIDE	21
12. DC LOAD INTRODUCTION	23
13. TYPICAL ARRAY SIZING GUIDE	23
14. WIRE DISTANCE CHART.....	24
15. SUGGESTED BATTERY CHARGER SET POINTS	25
16. CALLING THE FACTORY FOR ASSISTANCE	25
17. SPECIFICATIONS	26

SCOPE

This manual provides safety guidelines and installation information for the 45A/150V and 60A/150V Maximum Power Point Tracking Charge Controllers. It does not provide information about specific brands of solar panels and supplies limited information on batteries. Contact the supplier or manufacturer of the solar panels or batteries for further information.

INTRODUCTION

Important Safety Information

This manual contains important safety, installation and operating instructions for MPPT solar controller. The following symbols are used throughout this manual to indicate potentially dangerous conditions or mark important safety instructions, please take care when meeting these symbols.



WARNING : Indicates a potentially dangerous condition.

Use extreme caution when performing this task.



CAUTION : Indicates a critical procedure for safe and proper.



NOTE: Indicates a procedure or function that is important for the safe and proper operation of the controller.

The 45A and 60A Controller Maximum Power Point Tracking Charge Controllers *

The MPPT solar controller. Maximum Power Point Tracking Charge Controllers offer an efficient, safe, multi-stage recharging process that prolongs battery life and assures peak performance from a solar array. Each Charge Controller allows customized battery recharging. The Charge Controller features include:

- 60 amps maximum continuous output current up to 55°C without thermal derating for the 60A/150V and 45 amps for the 45A/150V
- Engineered to work with 12, 24 and 48VDC battery voltages
- Backlit LCD display screen
- Automatic cooling
- Voltage step-down capability allowing a higher PV array voltage configuration
- Manual and auto-equalize cycle

The following are the maximum recommended wattage for the most common solar arrays under Standard Test Conditions (1000 watts per square meter to solar panel at 25° C or 77° F):

- 12VDC battery systems-up to 800 watts (60A) or 600 watts (45A) of solar panels
- 24VDC battery systems-up to 1600 watts (60A) or 1200 watts (45A) of solar panels
- 48VDC battery systems-up to 3200 watts (60A) or 2400 watts (45A) of solar panels

Each Charge Controller also features Continuous Maximum Power Point Tracking (MPPT), which seeks out the maximum power available from a solar array and uses it to recharge the batteries. Without this feature, the solar array does not operate at the ideal operating voltage and can only recharge at the level of the battery voltage itself. Each Charge Controller continuously tracks the array's maximum operating power.

This manual covers the wiring, installation, and use of the Charge Controllers, including explanations of all the menus displayed on the LCD screen.

FIRMWARE

This manual covers Charge Controller firmware version 1.2.03

PC1600 CHARGE CONTROLLER INSTALLATION GUIDELINES AND SAFETY INSTRUCTIONS

This product is intended to be installed as part of a permanently grounded electrical system as shown in the system configuration sections (see pages 6-12) of this manual. The following important restrictions apply unless superseded by local or national codes:

- With the exception of certain telcom applications, the Charge Controller should never be positive grounded.
- The Charge Controller equipment ground is marked with this symbol: 
- If damaged or malfunctioning, the Charge Controller should only be disassembled and repaired by a qualified service center. Please contact your renewable energy dealer/installer for assistance. Incorrect reassembly risks malfunction, electric shock or fire.
- The Charge Controller is designed for indoor installation or installation inside a weather proof enclosure. It must not be exposed to rain and should be installed out of direct sunlight.

For routine, user-approved maintenance:

- Turn off all circuit breakers, including those to the solar modules, and related electrical connections before cleaning the air vents.

Standards and Requirements

All installations must comply with national and local electrical codes; professional installation is recommended. NEC requires ground protection for all residential PV installations

DC and Battery-Related Installation Requirements:

- All DC cables must meet local and national codes.
- Shut off all DC breakers before connecting any wiring.
- Torque all the Charge Controller's wire lugs and ground terminals to 35 inch-pounds (4 Nm).
- Copper wiring must be rated at 105°C or higher.
- Use up to 6 AWG (16mm²) to reduce losses and ensure high performance of Charge Controller (smaller cables can reduce performance and possibly damage the unit).
- Keep cables together (e.g., using a tie-wrap) as much as possible.
- Ensure both cables pass through the same knockout and conduit fittings to allow the inductive currents to cancel.
- DC battery over-current protection must be used as part of the installation. PC1600 offers fuses for overcurrent protection.

Battery Safety



WARNING WORKING IN THE VICINITY OF A LEAD ACID BATTERY IS DANGEROUS.

BATTERIES GENERATE EXPLOSIVE GASES DURING NORMAL OPERATION.

Design the battery enclosure to prevent accumulation and concentration of hydrogen gas in “pockets” at the top of the enclosure. Vent the battery compartment from the highest point to the outside. A sloped lid can also be used to direct the flow of hydrogen to the vent opening.



CAUTION To reduce risk of injury, charge only deep-cycle lead acid, lead antimony, lead calcium, gel cell or absorbed glass mat type rechargeable batteries. Other types of batteries may burst, causing personal injury and damage. Never charge a frozen battery.

PERSONAL PRECAUTIONS DURING INSTALLATION

- Someone should be within range of your voice to come to your aid if needed.
- Keep plenty of fresh water and soap nearby in case battery acid contacts skin, clothing, or eyes.
- Wear complete eye protection. Avoid touching eyes while working near batteries. Wash your hands with soap and warm water when done.
- If battery acid contacts skin or clothing, wash immediately with soap and water. If acid enters an eye, flood the eye with running cool water at once for at least 15 minutes and get medical attention immediately following.
- Baking soda neutralizes lead acid battery electrolyte. Keep a supply on hand in the area of the batteries.
- NEVER smoke or allow a spark or flame in vicinity of a battery or generator.
- Be extra cautious to reduce the risk of dropping a metal tool onto batteries. It could short-circuit the batteries or other electrical parts that can result in fire or explosion.
- Remove personal metal items such as rings, bracelets, necklaces, and watches when working with a battery or other electrical current. A battery can produce a short circuit current high enough to weld a ring or the like to metal, causing severe burns.

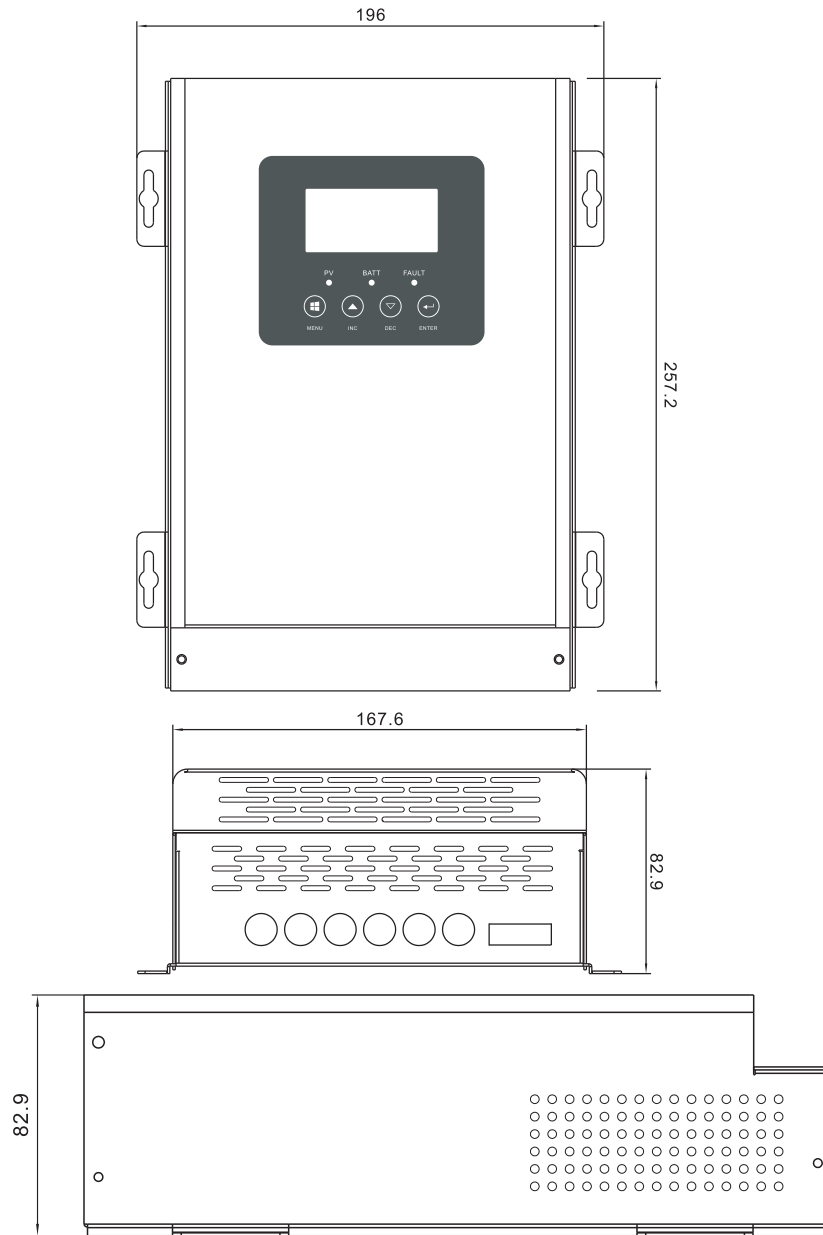

Figure 1 45A/60A Dimensions (Unit: mm)

1. INSTALLING THE Charge Controller

The intensional meaning of the marks letters on the Charge Controller:

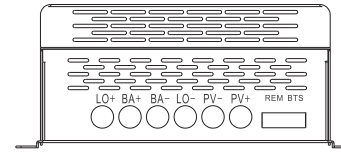

Figure 2 Charge Controller wiring compartment marks

Letter	Intensional meaning
LO+	The load positive terminal
BA+	The battery positive terminal
BA-	The battery negative terminal
LO-	The load negative terminal
PV-	PV array negative terminal
PV+	PV array positive terminal
REM:	Communication network terminal
BTS:	Remote external temperature terminal

Installing the Charge Controller

The Charge Controller is designed to attach directly to mounting on the wall.

• Step 1: Choose Mounting Location

Install the Charge Controller in an upright position out of direct sunlight, high temperature, and water.

• Step 2: Check for Clearance

Place the MPPT solar charge controller in the location where it will be mounted. Verify that there is sufficient room to run wires and that there is sufficient room above and below the controller for air flow.



NOTE: When mounting the MPPT solar charge controller, ensure free air through the charge controller surface. There should be at least 150mm of clearance above and below the controller to allow for cooling. If mounted in an enclosure, ventilation is highly recommended

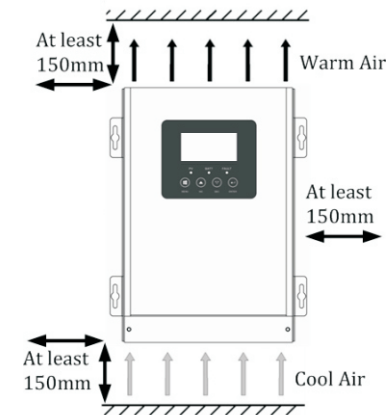

Figure 3 Mounting and cooling

• Step 3: Mark Holes

Use a pencil or pen to mark the four (4) mounting hole locations on the wall (mounting surface).

• Step 4: Drill Holes

Remove the Charge Controller and drill four sizeable holes in the marked locations.

• Step 5: Secure Controller

Insert all W 5/16-18 sheet metal screw through each hole and tighten against the wall.

WARNING : Risk of explosion!
Never install the MPPT solar controller in a sealed enclosure with flooded batteries! Do not install in a confined area where battery gas can accumulate.

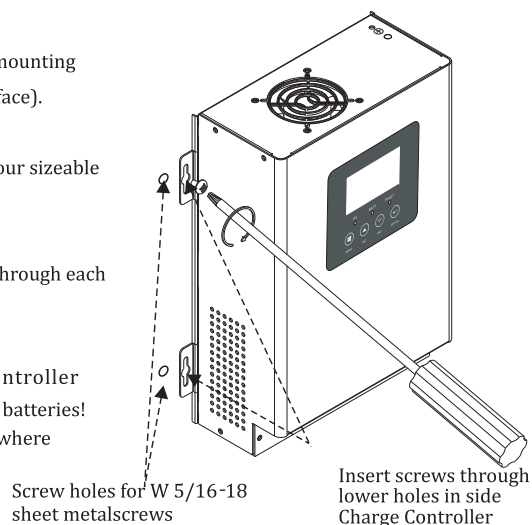

Figure 4 Installing the Charge

2. Open Circuit Voltage/Wire and Disconnect Size

Determining Wire Sizes

Maximum Open Circuit Voltage (VOC)

- VOC is the unloaded voltage generated by the solar array.
 - Greater than 145VDC → Charge Controller suspends operation to protect components
 - 147VDC → max open circuit voltage with the coldest environment

NOTE: Although the Charge Controller shuts down at a voltage greater than 145VDC, it can stand up to 147VDC from the array; anything higher than 147VDC will damage the Charge Controller.

- As every brand of panel is different, be sure to know the manufacturer's specifications.
- Weather conditions vary and will affect panel voltage.
 - Hot weather: lower open circuit voltage/lower maximum power point voltage
 - Cold weather: higher open circuit voltage/higher maximum power point voltage
 - Allow for ambient temperature correction using the following table:

25° to 10°C (77° to 50° F)	multiply VOC by 1.06
9° to 0°C (49° to 32° F)	multiply VOC by 1.10
-1° to -10°C (31° to 14° F)	multiply VOC by 1.13
-11° to -20°C (13° to -4° F)	multiply VOC by 1.17
-21° to -40°C (-5° to -40° F)	multiply VOC by 1.25

Check the PV array voltage before connecting it to the Charge Controller (see page 23 Typical Array Sizing Guide)

Wire and Disconnect Sizing

60A/150V

- The output current limit of the 60A/150V is 60 amps
- Use a minimum of 6 AWG (16 mm²) wire for the output between the 60A/150V and the battery bus bar conductors
- Install 80~150VDC breakers for disconnect and overcurrent protection
- The largest PV array that can connect to a Charge Controller must have a rated short-circuit current of 48 amps or less under STC (Standard Test Conditions).

45A/150V

- The output current limit of the 45A/150V is 45 amps
- Use a minimum of 6 AWG (16 mm²) wire for the output between the 45A/150V and the battery bus bar conductors
- Install 80~150VDC breakers for disconnect and overcurrent protection
- The largest PV array that can connect to a Charge Controller must have a rated short-circuit current of 36 amps or less under STC (Standard Test Conditions).



NOTE:

- Input conductors and circuit breakers must be rated at 1.56 times the short-circuit current of the PV array.
- MPPT Solar Controller 100% duty continuous breakers only need to be rated at 1.25 times the short-circuit current.

Please see the Wire Distance Chart and complete Wire and Disconnect Sizing on pages 24-25 for other suitable conductor/wire sizing.

3. Charge Controller Wiring Connections



NOTE: Do not entangle all wiring together, communication lines and power lines should be as far away as possible, to prevent interfering communication signal transmission.



NOTE: The MPPT Solar Controller is a negative ground controller. Any negative connection of solar or battery can be earth grounded as required. Grounding is recommended.



CAUTION : For mobile applications, be sure to secure all wiring. Use cable clamps to prevent cables from swaying when the vehicle is in motion. Unsecured cables create loose and resistive connections which may lead to excessive heating and/or fire.

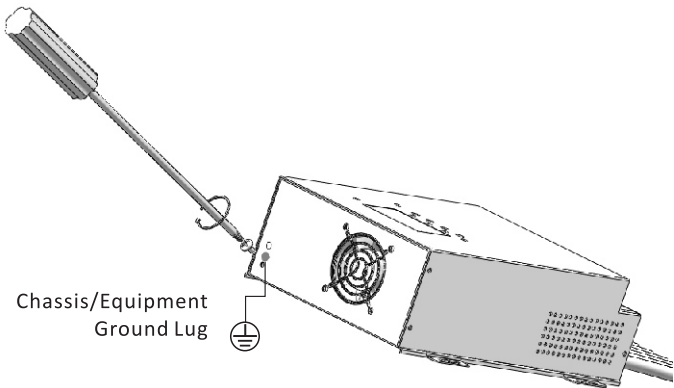

Figure 5 Charge Controller grounded

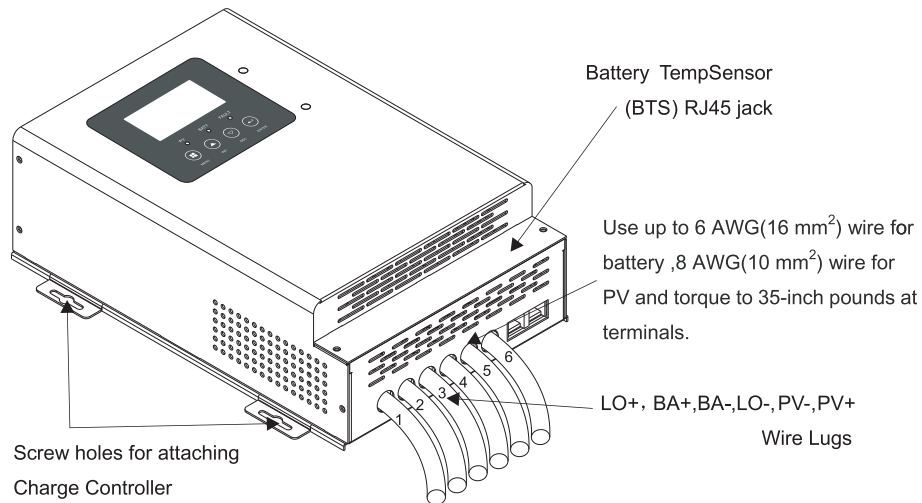

Figure 6 Charge Controller wiring compartment

The PV (-) and BAT (-) terminals are connected internally. Only one negative wire may be needed to connect to the (-) wire lugs if the PV- and BAT- conductors are bonded at the negative bus bar. See Figures 7, 8, 9 and 10 for sample wiring diagrams. See Wire and Disconnect Sizing on 24-25 for suitable conductor/wire sizing.



NOTE:

- Each Charge Controller requires its own PV array. DO NOT PARALLEL Charge Controller PV+ and PV- TERMINALS ON THE SAME ARRAY!
- An optional Battery Remote Temperature Sensor (BTS) is recommended for accurate battery recharging (only one BTS is needed for multiple the MPPT Series Solar Charge Controller units are a part of the system).
- The controller will not perform temperature compensation for charging parameters if the BTS is not used.



CAUTION : Equipment Damage! Never place the temperature sensor inside a battery. Both the BTS and the battery will be damaged.



WARNING : Risk of electric shock! Use fuses or breakers in solar and battery circuits is recommended, and be sure the PV input and battery breakers are off before starting the power-up sequence.

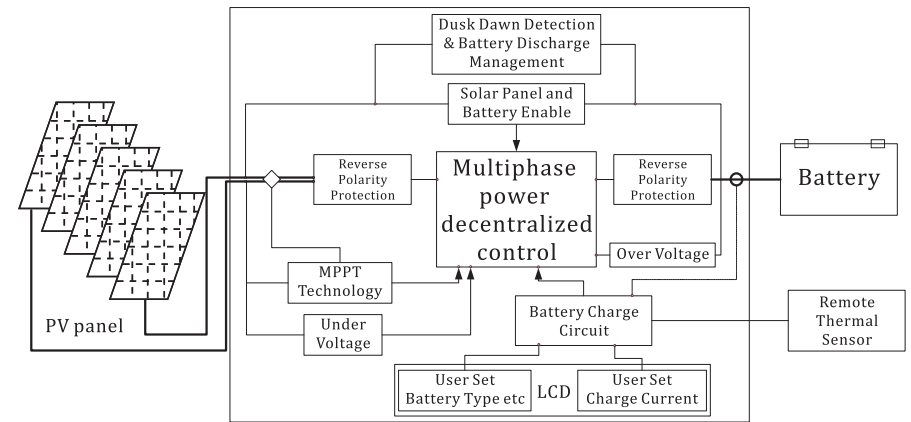

Figure 7 MPPT Solar Charge Controller Inner Topology

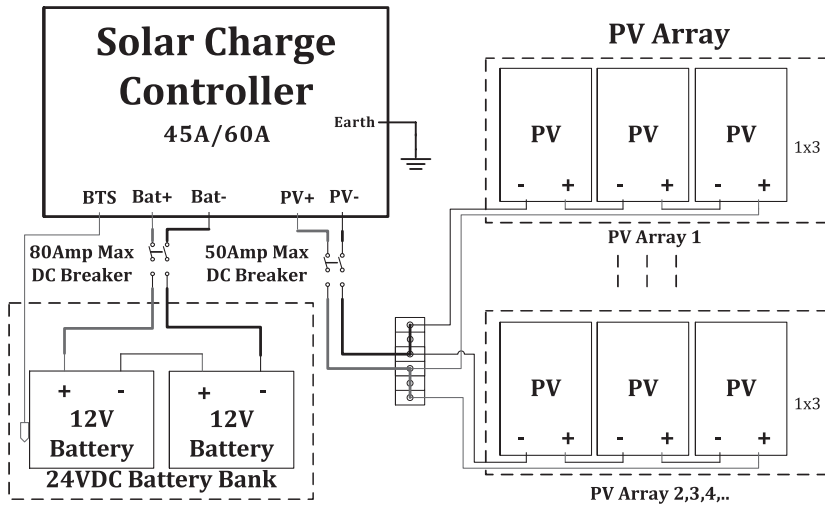

Figure 8 Single 45A Charge Controller wiring diagram with PV array and a BTS

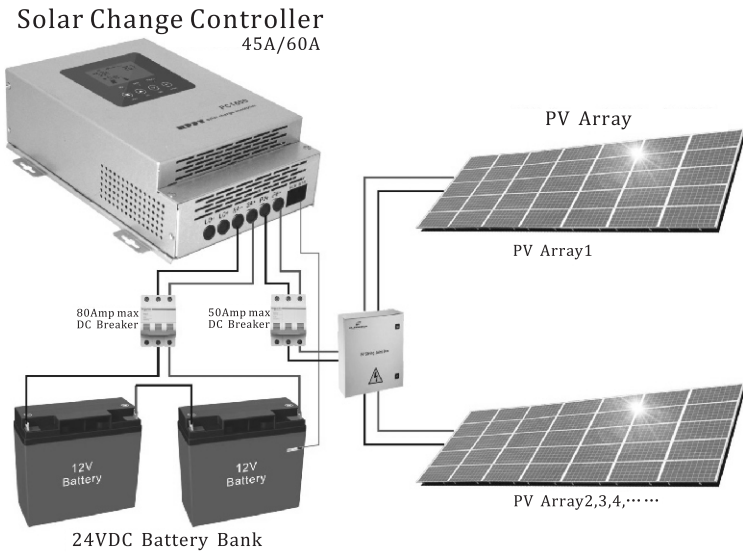

Figure 9 Single 45A Charge Controller wiring diagram with PV array and a BTS

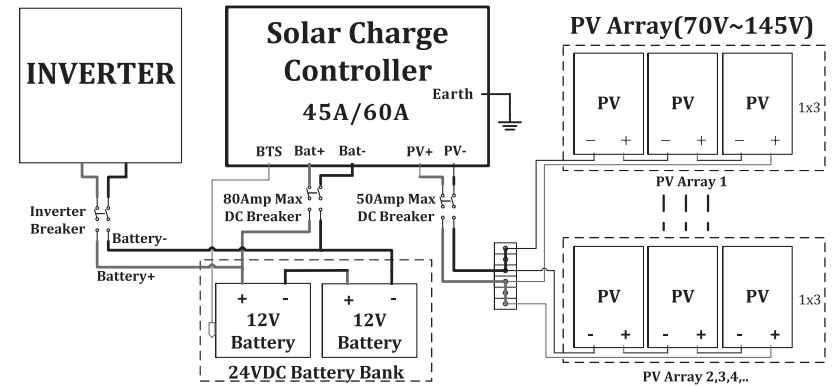
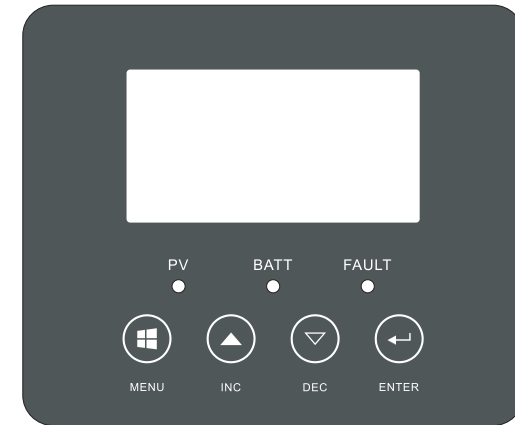

Figure 10 Single 45A Charge Controller wiring diagram with an inverter and a BTS

4. The Charge Controller Screen Description

Function keys:



Function Keys Description:

Function key	Description
MENU	Enter or exit setting mode.
INC	Increase the setting data.
DEC	Decrease the setting data.
ENTER	Confirm the selection in setting mode.

LED indicator

LED indicator			System status
PV	Green	On	PV voltage normal
		Flashing every 1s	PV fault is recovering
		Flashing every 2s	PV fault can't recover
		Off	PV is off
BATT	Yellow	On	Battery voltage normal
		Flashing every 1s	Battery fault is recovering
		Flashing every 2s	Battery fault can't recover
		Off	Battery is off
FAULT	Red	Flashing	Fault
		Off	Normal

5. POWER UP

The Charge Controller power-up sequence first activates the unit and the SELECT VERSION screen. A SYSTEM VOLTAGE screen soon follows.

PC1600 will auto-detects the system's battery voltage. The screens allow the user to adjust the Charge Controller working parameters (See Page16~18).





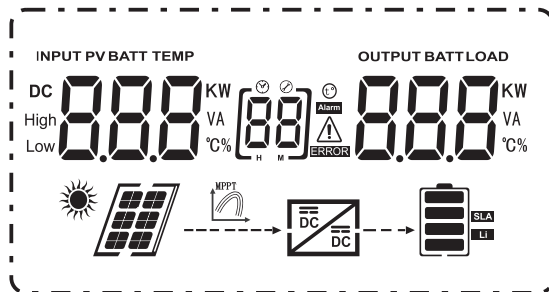

 **NOTE:** Only use the battery terminal's power source to start and operate the controller. The controller will not operate only from solar input.

6. STATUS SCREEN

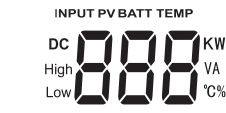
The STATUS Screen displays system information. See page16 for detailed information of the different Operational Modes.

LCD Display Indication



Indication	Function description
Display Information	
	Indicates PV voltage, battery voltage.
	Indicates output current, output power.
	Indicates battery type, battery capacity by 0-24%, 25-49%, 50-74% and 75-100% in charging status.
	Indicates MPPT solar charge controller work pattern.
Warning Information	
	Indicates the error codes.
Configuration Program	
	Indicates the setting programs.

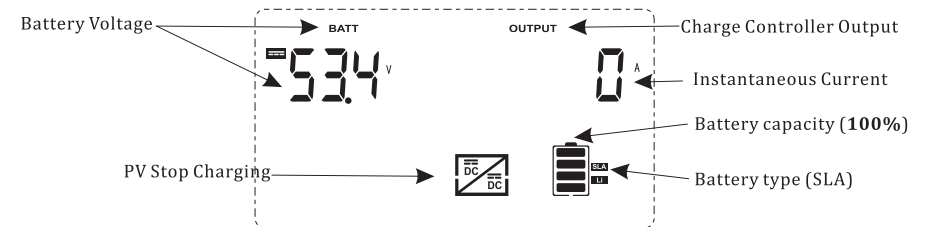

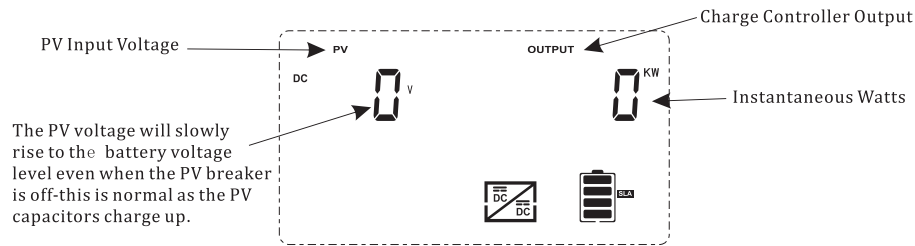

7. RECHARGING USING THE PV ARRAY

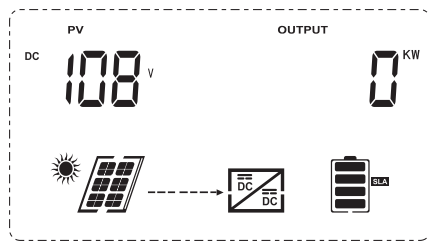

Turn the PV input breaker on. The Charge Controller automatically detects the PV input voltage.
(NOTE: If PV voltage registers "0V" when the breaker is on, please check the polarity of the PV wires.)

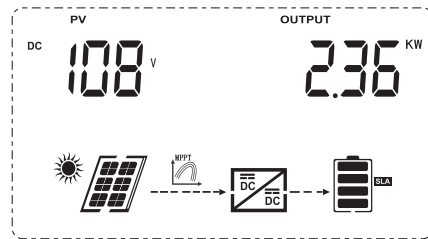

During the Charge Controller's initial tracking, the input source (e.g., solar) is gradually loaded from the open circuit voltage (VOC) to one-half of the VOC. Within this range, the Charge Controller seeks the maximum power point. When the Charge Controller goes into Absorb CC, Absorb CV, Float CC, Float CV, Silent modes, among other conditions, it performs an initial tracking

Operating Mode Description

Operation mode	Description	LCD display
01	MPPT charging	
02	Current-limiting output charging	
03	PV is unavailable	
04	PV stop charging	

8. ACCESSING THE MAIN MENU FOR PARAMETER SETTING

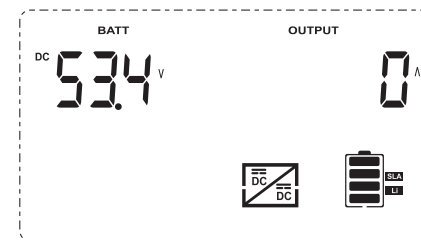

From the MAIN Menu, a user can choose among the following Charge Controller functions (Such as adjusts the Current Limit, Absorb, and Float recharging voltage set points) by aligning the arrow:

- **Work Enable:** Open or close the Charge Controller output.
- **Battery type:** Select the battery type (Lead acid or Lithium).
- **Battery AH:** Set the AH of the battery.

- **Absorb voltage:** Set the Absorb voltage (refer to the Charging Curve).
- **Refloat voltage:** Set the Refloat voltage (refer to the Charging Curve).
- **Float voltage:** Set the Float voltage (refer to the Charging Curve).
- **Max current:** The Max output current of the Charge Controller (refer to the Charging Curve).
- **Absorb current:** The absorb current of the Charge Controller (refer to the Charging Curve).
- **Low voltage Protect:** If the battery voltage is low than the set point, the Charge Controller will close the output.
- **High voltage Protect:** If the battery voltage is high than the set point, the Charge Controller will close the the output.

All of the above parameters after the setting is stored inside the Charge Controller, the Charge Controller can save these parameters, in order to shut down and then boot to run according to the last set value, no need to set second.

LCD Setting

After pressing and holding MENU button for 2 seconds, the unit will enter setting mode. Press “UP” or “DOWN” button to select setting programs. And then, press “ENTER” button to confirm the selection and exit.

Solar Charger working Switch	[01] ON	Open or close the Solar Charger Controller output
	[01] OFF	
Battery type	[02] Pb	Select the battery type(Lead acid or Lithium)
	[02] L	
Battery AH	[03] 200	Set the AH of the battery
Solar Charger absorb voltage	[04] 500 ^v	Set the Absorb voltage(Refer to theCharging Curve)

Solar Charger refloat voltage	[05] 548 ^v	Set the Refloat voltage(Refer to theCharging Curve)
Solar Charger Float voltage	[06] 572 ^v	Set the Float voltage(Refer to theCharging Curve)
Solar Charger max current	[07] 600 ^A	Set the max output current of the Solar Charge Controller(Refer to the Charging Curve)
Solar Charger absorb current	[08] 150 ^A	Set the absorb current of the Solar Charge Controller(Refer to the Charging Curve)
Solar Charger low DC cut-off voltage	[09] 400 ^v	If the battery voltage is lower than the set point, the Solar Charge Controller will close the output
Solar Charger high DC cut-off voltage	[10] 600 ^v	If the battery voltage is higher than the set point, the Solar Charge Controller will close the output

Note that setting data absorb voltage must be less than to Refloat voltage, and Refloat voltage must be less than the float voltage, when the set of data has conflict with each other, the system can't run.

9. Charge Controller MULTI-STAGE BATTERY CHARGING

brief introduction

The Charge Controller is a sophisticated, multi-stage battery charger that uses several regulation stages to allow fast recharging of the battery system while ensuring a long battery life. The Charge Controller has a preset recharging voltage set points (Absorb & ReFloat & Float) for the selected nominal battery voltage, however, always follow the battery manufacturer's recommended charging regulation voltages.

If Lead acid is selected in program 02, the Controller charging regulation stages correspond to the chart in Figure 11 as shown below.

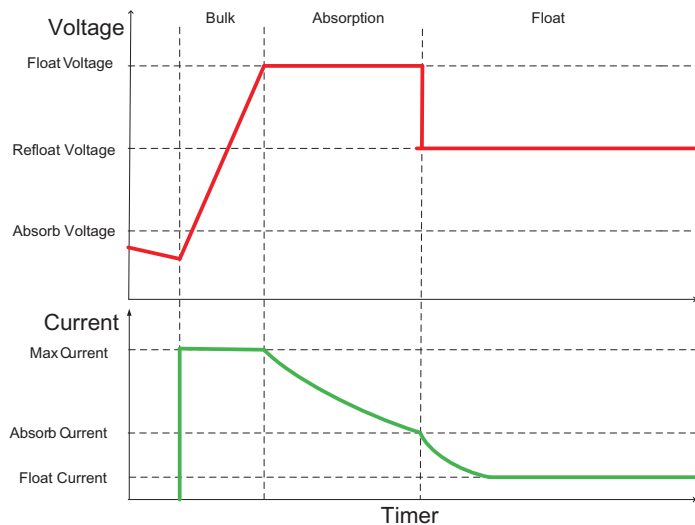

Figure 11 charging algorithm for Lead acid battery

- 1) Bulk stage. In bulk charge stage, charge current begins to flow, typically at the maximum rate of the charge source. The controller will supply solar power to charge battery as much as possible.
- 2) Absorption stage. When battery charging voltage is reached to Absorption voltage point, the charging stage changes from bulk charge to Absorption. Constant-voltage regulation is used to maintain battery voltage at the Absorption stage. If the charging current drops to Absorb Voltage current setting point, the charging status will change to Float stage.

- 3) Float Stage. After the battery is fully charged in the Absorption stage, the controller will reduce the battery voltage to the setting point of Float voltage. Once in Float stage, constant-voltage regulation is used to maintain battery voltage at setting point of float voltage.

If Lithium is selected in program 02, the Controller charging regulation stages correspond to the chart in Figure 12 as shown below.

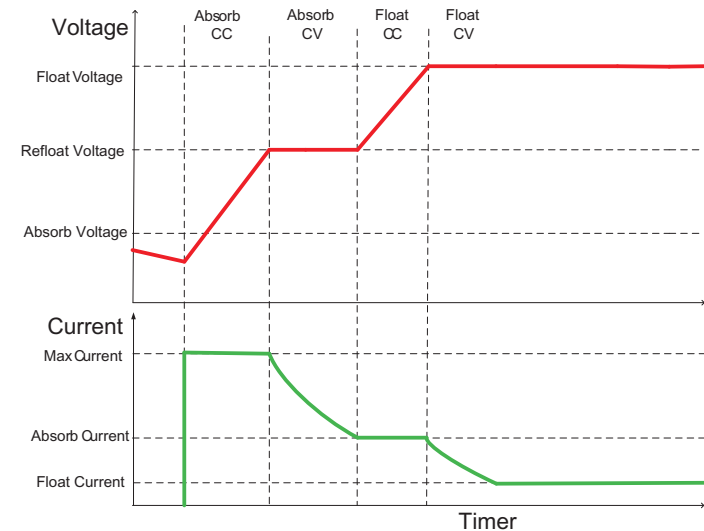

Figure 12 charging algorithm for Lithium battery

When the battery voltage is lower than the absorb voltage, solar controller will trigger a charge cycle.

- 1) Constant current absorb charge stage provides the maximum power to the battery the voltage increases while recharging. A constant current absorb charging cycle is automatically initiated when the battery voltage is below the Absorb voltage set points. If the PV array power is not enough, the Charge Controller is in Maximum Power Point Tracking mode trying to regulate the battery voltage towards the Absorb voltage set points. The constant current absorb charge state will continue until the ReFloat voltage set point is achieved, the Charge Controller will switch to the constant voltage absorb charge stage.

2) When in the constant voltage absorb charge stage, the Charge Controller is regulating the battery voltage at the Refloat voltage set point. During this cycle, a counter is counting up towards the defined absorb time limit. If the system cannot regulate the battery voltage at the Refloat voltage set point, then the Charge Controller reverts back to the constant current absorb charge stage, and the counter may start counting down towards zero minutes or until the absorb target is met. While the battery voltage is at or above the Absorb target and the absorb end Amps value is reached for a time delay of 30 seconds, the Charge Controller will switch to the constant current float stage.

3) A Float cycle follows after the Absorb cycle is completed. The Charge Controller will re-initiate another Absorb cycle if the Refloat voltage set point is not sustained. The Charge Controller is in the constant current float charge stage and is regulating the current at the Absorb current set point. If the system cannot maintain the Absorb current set point, the Charge Controller will employ the MPPT function, and try its best to regulate the batteries to the Float voltage set point. The constant current float charge state will continue until the Refloat voltage set point is achieved, the Charge Controller will switch to the constant voltage absorb charge stage.

4) When in the constant voltage float charge stage, the Charge Controller is regulating the battery voltage at the Float voltage set point. The charger Controller will reduce the output current until the current is at the float end amps.

5) While the battery voltage is at or above the Float voltage target and the Float end Amps value is reached for a time delay of 30 seconds, the Charge Controller will switch to the silent stage, power off the output.

 **WARNING:** Risk of explosion!
Equalizing flooded battery can produce explosive gases, so well ventilation of battery box is necessary.

 **CAUTION:** Equipment damage!
Over-charging and excessive gas precipitation may damage the battery plates and activate material shedding on them. Too high an equalizing charge or for too long may cause damage. Please carefully review the specific requirements of the battery used in the system.

10. Charge Controller EFFICIENCY vs. INPUT POWER GRAPH

The Charge Controller modes of operation will change occasionally during the day based on the PV array output and the battery system state of charge. The Charge Controller operating modes are displayed at the bottom right hand corner of the STATUS screen.

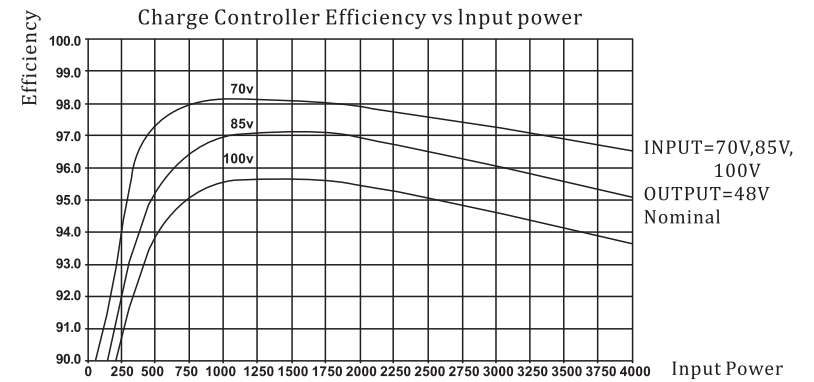













Figure 12 48V Battery System Efficiency Curve

11. Troubleshooting Guide

Fault Code	Fault Cause	LCD Indication
01	Battery voltage class error	
02	Hardware protection	
03	Over current	
04	Battery voltage is too low	
05	Battery voltage is too high	
06	Current is uncontrollable	
07	Over temperature	
08	Current sensor error	
09	PV voltage is too high	
10	Fan fault	
11	Voltage point setting error	

Charge Controller does not boot/power up (blank LCD)

- Check the battery connection and polarity.
 - Reverse polarity or an improper connection will cause power-up issues.
- Check the battery breaker.
 - Ensure that the battery breaker is sized appropriately.
- A battery voltage below 10.5VDC may not power up the Charge Controller (measure the battery side of wire lugs).
- If the Charge Controller still does not power up, call the factory for additional support.

Charge Controller is always SLEEPING

- If the battery voltage is at or above the Absorb voltage set point (compensated Absorbvoltage), the Charge Controller will not wake up.
- The PV voltage has to be at least the lowest volts for the initial wakeup.
The lowest volts for the initial wakeup: 16V for 12V battery system

32V for 24V battery system

64V for 48V battery system

- Check the PV array breaker (or fuse).
- Confirm the PV array breaker (or fuse) is sized appropriately.
- Have you checked the short circuit current of the PV array?
 - Use a multi-meter to determine if a short circuit current is detected. The short circuit test will not harm the array.

Charge Controller not producing expected power

- Clouds, partial shading, or dirty panels can cause poor performance.
- The lower current limit set point in the Charger menu will yield a loss of power or poor performance symptoms.
- Are the batteries charged? Is the Charge Controller in the Absorb or Float stage? If either case is true, the Charge Controller will produce enough power to regulate the voltage at the Absorb or Float set point voltage, therefore, requiring less power in these modes.
- What is the short circuit current of the PV array? Use a multi-meter to determine if a short circuit current is as expected. There might be a loose PV array connection.
- If the PV array voltage is close to the battery voltage, the panels could be warm/hot causing the Maximum Power Point to be at or lower than the battery voltage.

Charge Controller Internal Fan

- The internal fan will only run when the internal temperature has reached approximately 45°C. The fan will continue running until the internal temperature is less than 35°C.

12. DC LOAD INTRODUCTION

DC load can Continuous discharge, but the max output current for DC load is 60 amps for the 60A/150V and 45 amps for the 45A/150V, DC load input voltage should be coincident with battery voltage.

Battery voltage will rise accordingly with the process of charging, if the DC load input voltage not wide enough, it will damage easily. So please make sure the max input voltage of DC load should be higher than the max charging voltage of solar charge controller.



NOTE: Over-discharge will damage the bank of batteries, please make sure each battery voltage is always higher than 10.5VDC.

13. Typical Array Sizing Guide

Below is a list of recommended array sizing for the Charge Controller for various nominal voltage batteries:

Nominal Battery Voltage	Recommended Array Size (in watts, Standard Test Conditions)	
	12V	600W
24V	1200W	1600W
48V	2400W	3200W

The Charge Controller PV MPPT Charge Controller is capable of an input open circuit voltage (VOC) of up to 147 VDC. Cooler climates can cause the VOC to rise above the panel VOC rating. In climates that observe temperatures less than approximately -15°C, a VOC greater than 125 VDC is not recommended.

When sizing an array, it is recommended that the nominal array voltage be higher than the nominal battery voltage. Below is a list of recommended nominal array sizing:

Nominal Battery Voltage	Nominal Array Voltage (recommended)
12V/24V /48V	16V~100V for 12V battery system
	32V~145V for 24V battery system
	64V~145V for 48V battery system

* When sizing an array to charge controller with a distance of 70 feet or greater, MPPT Solar Controller recommends the nominal array voltage be slightly higher than the recommended nominal array voltage. Sizing the nominal array voltage higher than the nominal battery voltage ensures that the Maximum Power

Point is always above the battery voltage. The Maximum Power Point will decrease as the panels warm up, thus lowering the output of the array. The Charge Controller will not be able to boost the output if the Maximum Power Point of the array is at or lower than the battery voltage.

14. Wire Distance Chart

To meet NEC compliance (North America), the largest PV array that can be connected to a 60A/150V must have a rated short-circuit current of 48 amps or less and 36 amps or less for a 40A/150V. The following charts show the maximum distance of various gauge two-conductor copper wire from the PV array to the Charge Controller with a 1.5% maximum voltage drop. Temperature and conduit fill corrections may be required. Using a higher voltage PV array with a low voltage battery system allows you to use a much smaller wire size or go up to 5 times as far with the same gauge wire.

WIRE AND DISCONNECT SIZING

The 60A/150V has a 60 amp current output limit (default) and is listed to operate continuously at 60 amps depending on the nominal PV array voltage and the nominal battery voltage. There is no 80% derating as required by the NEC* for fuses, conductors, and most circuit breakers.

The 60A/150V is a buck type converter and cannot boost the output current when the PV array peak power point voltage is at or below the battery voltage as may happen on hot days in 24 VDC PV and a 24 VDC battery system or a 48 VDC PV and a 48 VDC battery system.

To meet minimum NEC requirements (NEC 310.15, 690.8, 9), the output conductor should have an ampacity of 75 amps after any temperature and conduit fill corrections. This would normally indicate that the output conductors be 6 AWG (16 mm²), but a larger size may be required if there are temperature and/or conduit fill corrections required.

The PV array output connected to the 60A/150V input may be as high 60 amps, but at this current level, there is very little (if any) current boosting or maximum power-point tracking due to the 60-amp output current limit. Additionally, the input current may exceed 60 amps on bright sunny days and any excess power would be lost. The size and ampacity of the input conductors must be selected to handle 1.56 times the short-circuit current of the PV array. Any disconnect or circuit breaker connected to the input conductors must also be rated at 1.56** times the short-circuit current for the PV array unless the breaker is rated for 100% duty in its enclosure. If that is the case, the circuit breaker may be rated at 1.25 times the PV array short-circuit current.

In terms of NEC compliance and the 60A/150V 'S 60-amp output rating, the largest PV array it can connect to should have a rated short-circuit current of 48 amps. This meets NEC requirements and allows the 60A/150V to perform maximum power-point tracking functions. The following charts

show maximum distance in feet of various gauge two-conductor copper wire from the PV array to the 60A/150V with a 1.5% maximum voltage drop. Temperature and conduit fill corrections may be required.

*When NEC does not apply, see local code requirements.

15. SUGGESTED BATTERY CHARGER SET POINTS

The battery manufacturer should provide you with specific instructions on the following maintenance and voltage set point limits for the specific batteries. The following information can be used when the manufacturer's information is not available.

Battery type	Voltage Point Setting	12V	24V	48V
SEALED LEAD ACID AGM/GEL NONSEALED LEAD ACID	Absorption Voltage	12.5V	25.0V	50.0V
	Refloat Voltage	13.7V	27.4V	54.8V
	Float Voltage	14.3V	28.6V	57.2V
LITHIUM	Absorption Voltage	13.2V	26.4V	52.8V
	Refloat Voltage	13.4V	26.8V	53.6V
	Float Voltage	13.5V	27.0V	54.0V

Battery Voltage and State of Charge

A battery's voltage can be used as a guideline to estimate the amount of power stored in the battery that is available for use. When referencing the battery voltage on the display, be sure the battery is not under significant recharging or heavy loads. Otherwise, the DC voltage is not reflective of the battery state of cycle. Often the best time to check the battery voltage is in the morning (pre-charging) or at night (post-charging), with the battery disconnected from charging sources and loads and a rest for at least three hours.

Operation of a battery below 50% state of cycle will adversely affect the long term health of the battery system and will result in premature failure. Keeping the battery above the 50% level and recharging it completely once a month will ensure proper operation and good performance.

16. CALLING THE FACTORY FOR ASSISTANCE

When calling us for product assistance, please have the following information ready:

- Charge Controller Serial number
- The nominal PV array and battery voltage.
- The PV array operating voltage and battery current and any Status screen operational mode displays, such as MPPT Status,ERR Code etc.

17. SPECIFICATIONS

Model	45A	60A
Default Battery System Voltage	12V/24V/ 48VDC (Auto Detection)	
Charge Input		
PV Open Circuit Voltage	100V/145V	
PV Array MPPT Voltage Range	16V-100V/32V-130V/ 64V-130V	
Max PV Input Power(12V)	600W	800W
Max PV Input Power(24V)	1200W	1600W
Max PV Input Power(36V)	1800W	2400W
Max PV Input Power(48V)	2400W	3200W
Storage Battery Voltage		
Nominal Voltage	12VDC/24VDC/48 VDC	
Absorption Voltage	12.5VDC/25.0VDC/ 50.0VDC	
Refloat Voltage	13.7VDC/27.4 VDC/54.8 VDC	
Float Voltage	14.3VDC/28.6 VDC/57.2 VDC	
Low Voltage Protection Point	10.0VDC/20.0 VDC/40.0 VDC	
Temperature compensation coefficient	-3 mV / °C / cell (25 °C ref.)	
DC Output		
Output Voltage	11.0-14.3VDC/22.0-28.6VDC/44V-57.2VDC	
Max ChargingCurrent	45A amps continuous @ 40°C ambient	60 amps continuous @ 40°C ambient
Warning for low voltage	11.5VDC/23.0 VDC/46.0VDC	
Cut off for low voltage	10.5VDC/21.0 VDC/42.0 VDC	
Low voltage recovery	11.5VDC/23.0 VDC/46.0VDC	
Display		
LED indication	Systematic operation, LV indication, LV protection, over charge protection, loads protection, short circuit protection	
LCD display	Charge voltage, charge current, voltage of storage battery, capacity of storage battery, output current	
Alarm Protections	PV array short circuit, PV reverser polarity	
	Battery reverse polarity, Over charging protection	
	Output short circuit protection	
	Low voltage protection for storage battery	
General specification		
Environmental Rating	Indoor	
Charge mode	MPPT, PWM,constant current—constant voltage, function of automatic protection for storage battery	
Radiating mode	Fan cooling	
Working mode	Fourstage: Absorption CC, Absorption CV, Float CC, Float CV.	
Peak Conversion efficiency	98%	
Environment		
Environmental temperature	-25°C ~55°C	
Ambient humidity	0--90%, No condensation	
Altitude	≤3000m	
Dimension		
W*H* D(mm)/G.W(kg)	167.6*257.1*82.9mm/3kg	